







N f\_ 4=bc [







0	NB YL	Ch	
0	NB YL	Ch	
0	NB YNE	I	
0	NB YNE	I	
.	NB YLE	Ch	
.	NB YLE	Ch	
.	NB YNE	I	
.	NB YNE	I	
,	NB YLE	Ch	
,	NB YLE	Ch	
,	NB YNE	I	
,	NB YNE	I	
-	NB YL Y=FEYH	Ch	
A -	NB YL Y=FEYJ	Ch	

b\_h\_ Ji /0(/GB \_\_\_h]\_ ]fi)e  
FP Mf\_fCh (

N f / 4 = C

S	J YQ E	I	Q E ah[f ch Ch J=C
S,	J LMNYH	Ch	J=C [ h]b i hi
N	J YL Y=FEYJ	Ch	J=C GB ___h]_ ]fi)e
O	J YL Y=FEYH	Ch	
P.	J YNR YJ Y	I	=GF c __h d f ah[f J=C _ JBS
Q.	J YNR YH Y	I	c __h d f [c (
.	J YLR YJ Y	Ch	
.	J YLR YH Y	Ch	
P 0	J YNR YJ Y	I	
Q 0	J YNR YH Y	I	
0	J YLR YJ Y	Ch	
0	J YLR YH Y	Ch	
P 2	J YNR YJ Y,	I	
Q 2	J YNR YH Y,	I	
2	J YLR YJ Y,	Ch	
2	J YLR YH Y,	Ch	
P	J YNR YJ Y-	I	
Q	J YNR YH Y-	I	
	J YLR YJ Y-	Ch	
	J YLR YH Y-	Ch	
P ,	J YNR YJ Y	I	
Q ,	J YNR YH Y	I	
,	J YLR YJ Y	Ch	
,	J YLR YH Y	Ch	
P .	J YNR YJ Y/	I	



J-	F H YAJD Y/		
H/	F H YAJD Y0		
J	F H YAJD YI		
J.	F H YAJD Y		
J/	F H YAJD Y		
L.	F H YAJD Y,		
L,	F H YAJD Y-		
L-	F H YAJD Y.		
N	F H YAJD Y/		
L/	F H YAJD Y0		
N	F H YAJD YI		

### N f<sub>3</sub>GHAYAJD

L,	GHAYAJD Y	c c	Ohc _ [fch [h i dh i dh_h[f_g _ _
L 3	GHAYAJD Y		=JO c hi _ ][h_f_ h]ihh] _ (
J 2	GHAYAJD Y,		
J 3	GHAYAJD Y-		
L,,	GHAYAJD Y.		
J,,	GHAYAJD Y/		
H 2	GHAYAJD Y0		
J,	GHAYAJD YI		

### N f<sub>4</sub>H=MC

N,	LG CYNR Y	I	H=MC [h g c [ [
L 2	LG CYNR Y		
O,	LG CYNRY H	I	N[h g c h[ f
P,	LG C=MLY P	Gh	=[ c Mh )L ] c _ [ [ P[fc
P,,	LG CYL Y=FE	Gh	H=MC _ h] ]fi)e
O,,	LG CCLR Y	Gh	H=MC ]_c _ [ [
N	LG CCLR Y		

### N f<sub>4</sub>CCG D

L,	G CCG	c c	C H=MC c ]ihh] _ i JBS bc Gh _ []_c _ i
N	G CCG =	I	]ih if b_JBS i b _ c _ c hi ]ihh] _ _ [ f(

### N f<sub>5</sub>, C=

,	C= YM F	c c	C= Gh _ []_ i f[ _ gi f_]ih ca [ dh Gh A JBS
-	C= YM		

A-	Ⓒ YM		
	Ⓒ YMF		

### N f\_ - 4 G I

O	G Y=FE	I	O _ i ]h if_ _h[fJBS c M c da _ _h[fJBS (
P,	G YI	c c	
O-	G Y=FE	I	
N	G YI	c c	

### N f\_ . 4GHAMG

D	GHAYⒸY N	I	MG i ih ]bc =JO
E	GHAYⒸYMG F LNH	I	
E-	GHAYⒸYMG MDMH	I	
E/	GHAYⒸY=FE	I	

### N f\_ / 4 i \_

,,	JL Y H	Ⓒ	N_ da Ⓒh[f(Nb_ [ _hi _ Ⓒ hi g[f i _[ Ⓒh (
,	JL YBCN	I	
H,	JL Y=FEI ONJON		
H,,	JL Y N Y		
H,	JL Y N Y		
G 3	JL Y N Y,		
G,	JL Y N Y-		
G 2	JL Y N Y.		
G,,	JL Y N Y/		
F 2	JL Y N Y0		
G,	JL Y N Y1		
F,	JL Y N Y2		
F,,	JL Y N Y3		
F 3	JL Y N Y		
E,	JL Y N Y,		
E,,	JL Y N Y,		
E,	JL Y N Y-		
D,	JL Y N Y.		
E 2	JL Y N Y/		
D	JL Y N Y0		
D3	JL Y N Y1		
D	JL Y N Y2		
D2	JL Y N Y3		



NETSWIFT  
网迅科技





<p>Q1 S1 1 1 =2 2  A2 F2 H2 O2 S2 3 3  =3 3 3 E3 G3 J3 P3  Q3 S3 3 3 =  A D F H N O  S =  E G J L  P Q S  = , , D, F, H, N,  O, S, - - = -  - - E - G - J -  P - Q - S - - -  = . . A . D . F . H .  O . S . / / = /  / / E / G / J /  L / O / P / Q / S /  / / = 0 0 B 0  L 0 O 0 S 0 1 1  = 1 1 1 1 A 1 B 1  L 1 N 1 O 1 P 1 Q 1  S 1 1 1 = 2 2  N 2 O 2 S 2 3 3  = 3 3 3 A 3 E 3  H 3 N 3 P 3 Q 3 S 3  3 3 , , B, F, J, O,  , , , , ,  ,,</p>		
<p>E2 D F3 E D F  E, D- F- E. D/ F/</p>	<p>P Y Y J3</p>	<p>Ji f i cac[f  (3P( Cg _[f [  I H(</p>
<p>G2 J2 H3 G J H  G, J, H- G. J.  H/</p>	<p>P G Y Y J3</p>	<p>Ji f i cac[f (3P  b[ ][h _ b i h  fi i _ [_(</p>
<p>D</p>	<p>PM Y J3</p>	<p>A i h i [h[fi a (3P</p>
<p>D E0 F0 G0 H0 J0 D1  E 1 F 1 G 1 H 1 J 1</p>	<p>PM Y J2</p>	<p>A i h i cac[f (2P</p>







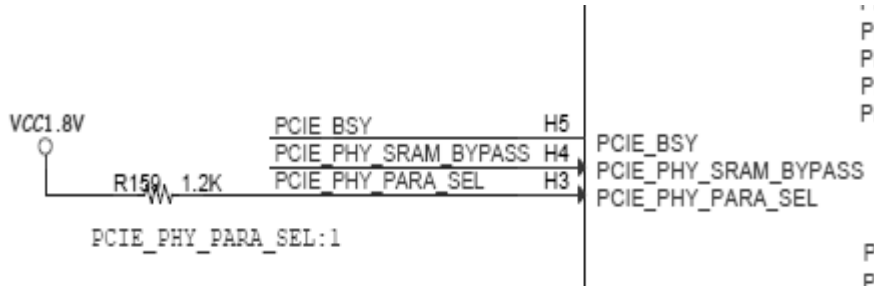
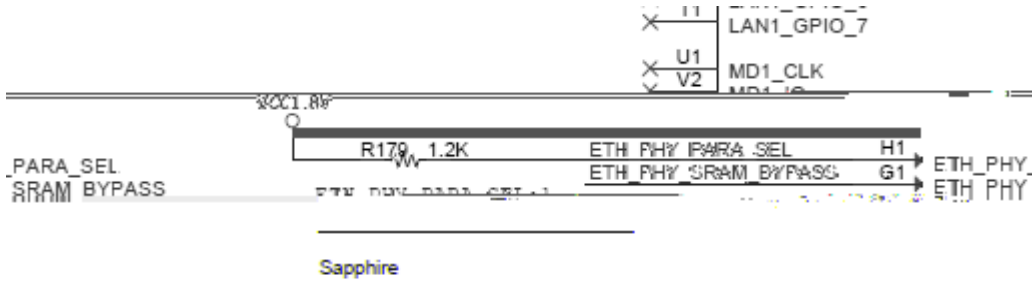

M J=C YJBS YML G Y S J MM NB YJBS YML G Y S J MM F H Y CMH  
 F H, Y CMH  
 M NB YL ML NB YL ML J YJBS YL ML J YJBS YL ML

NB YL Y=FEYJ NB YL Y=FEYH /0G /GBT  
 NB YL Y=FEYJ NB YL Y=FEYH /0G /GBT (2P  
 FP M = = FP M  
 NB YL Y=FEYJ NB YL Y=FEYH NB YL Y=FEYJ NB YL Y=FEYH  
 =

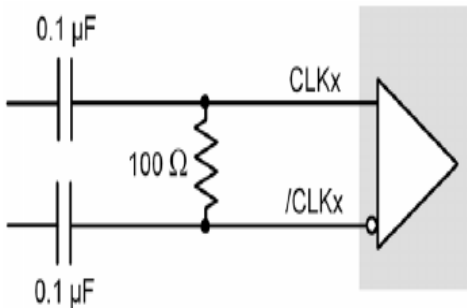

SP1000A



### ■ Avoid tight bends

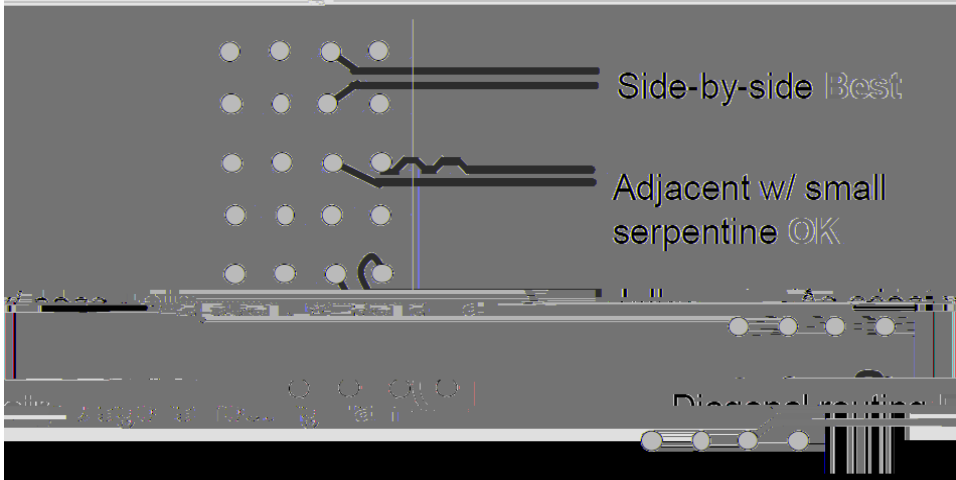

•

•

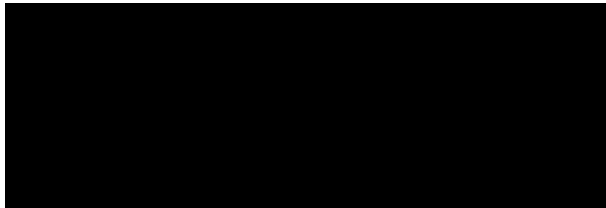

•

•

•

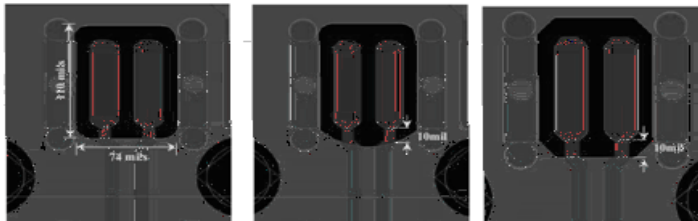

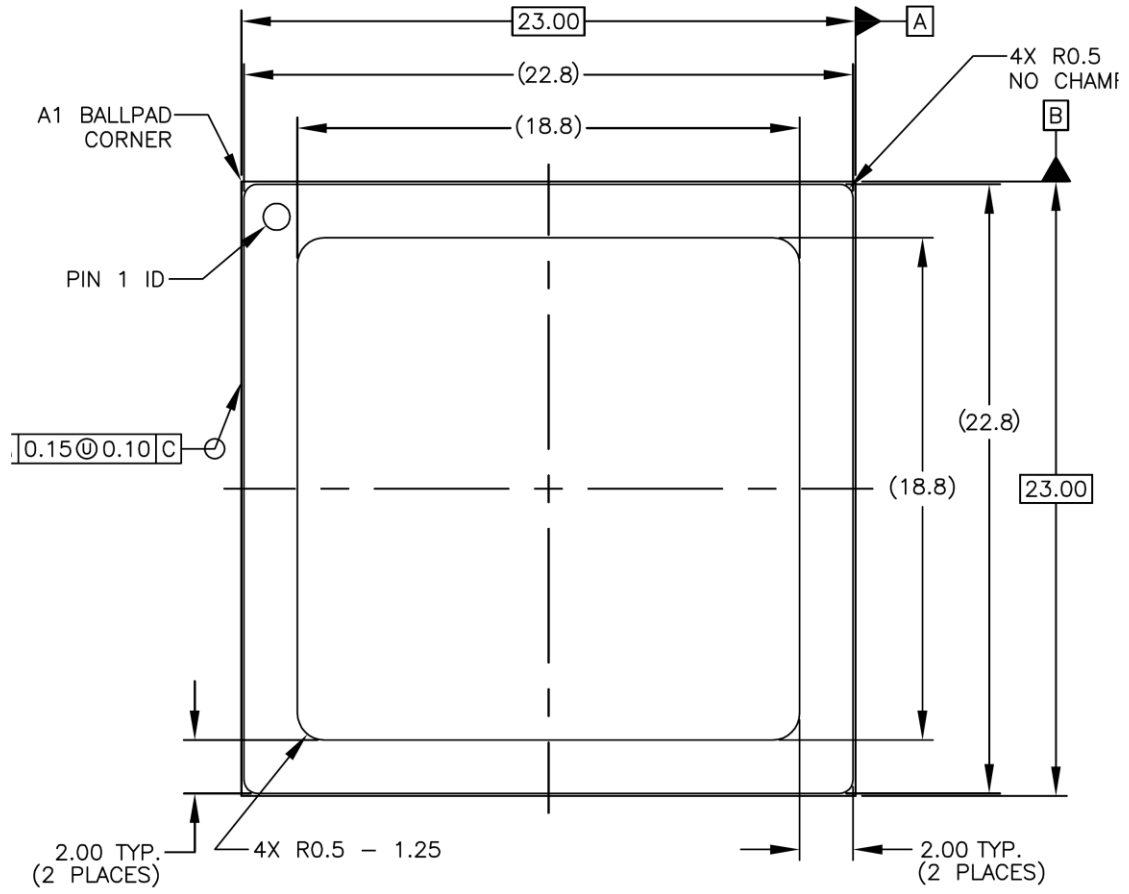

TOP VIEW

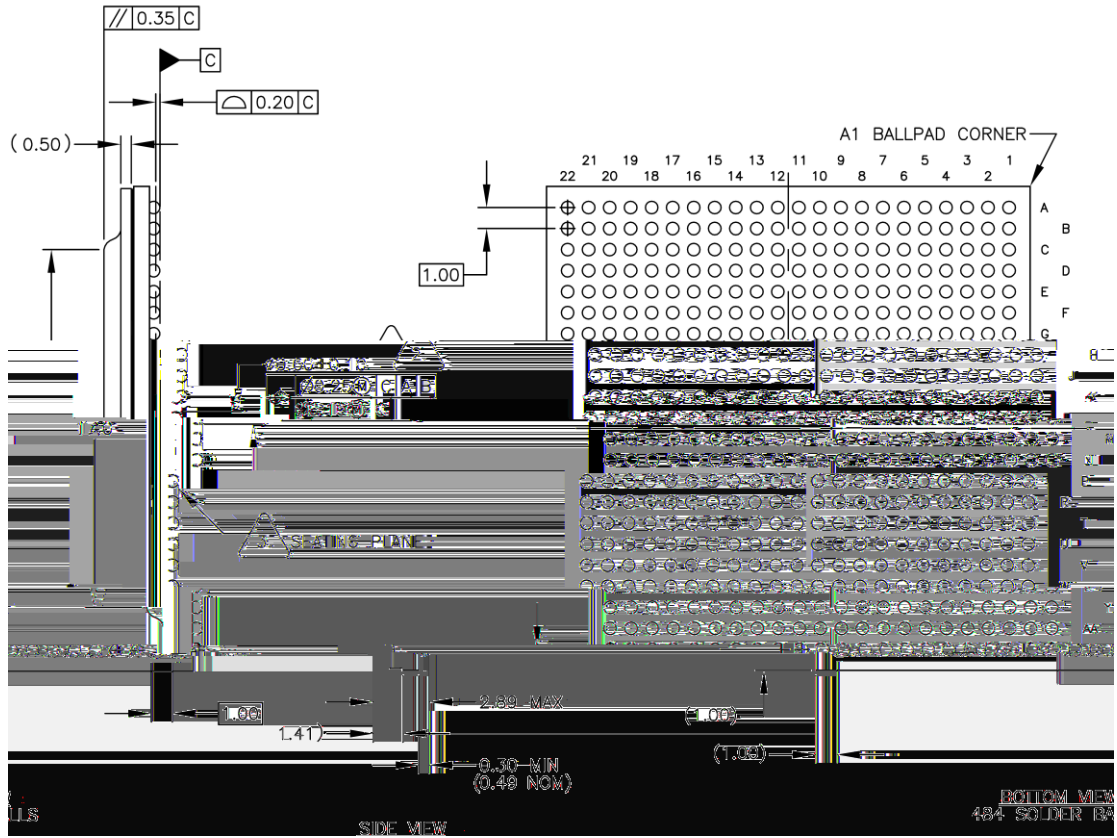

№ , /